

Modeling of Gas Hydrate Formation in the Presence of Inhibitors by Intelligent Systems

Mohammad-javad Jalalnejhad^{*1,2}, Mohammad Ranjbar³, Amir Sarafi⁴
And Hossein Nezamabadi-Pour⁵

¹Department of Petroleum Engineering, Shahid Bahonar University of Kerman, Kerman, Iran

²Young Researchers Society, Shahid Bahonar University of Kerman, Kerman, Iran

³Department of Mining Engineering, Shahid Bahonar University of Kerman, Kerman, Iran

⁴Department of Chemical Engineering, Shahid Bahonar University of Kerman, Kerman, Iran

⁵Department of Electrical Engineering, Shahid Bahonar University of Kerman, Kerman, Iran

(Received 16 May 2013, Accepted 1 November 2015)

Abstract

Gas hydrate formation in production and transmission pipelines and consequent plugging of these lines have been a major flow-assurance concern of the oil and gas industry for the last 75 years. Gas hydrate formation rate is one of the most important topics related to the kinetics of the process of gas hydrate crystallization. The main purpose of this study is investigating phenomenon of gas hydrate formation with the Presence of kinetic Inhibitors in operation gas transmission, and prediction of gas hydrate formation rate in the pipeline. In this regard, by using experimental data and Intelligent Systems (Artificial neural networks and adaptive neural-fuzzy system), two different high efficient and accurate models were designed to predict hydrate formation rate of CO₂, C₁, C₃, and i-C₄. It was found that such models can be used as powerful tools, for prediction of gas hydrate formation rate with total average of absolute deviation less than 6%.

Keywords: Fuzzy Inference System, Artificial neural network, Gas hydrate formation, Kinetic inhibitor, Rate model.

1. Introduction

Hydrates are crystalline clathrate compounds composed of water and light gases. Natural gas hydrates are defined as clathrates that contain the following molecules as guests: light hydrocarbons up to the size of normal butane, and impurities often found in natural gas, such as, hydrogen-sulfide, carbon dioxide, and nitrogen. Although clathrates have similar properties to ice, they differ in that they may form at temperatures well above the freezing point of water at elevated pressure conditions [1]. With the development of the natural gas industry in the 20th century, the production, processing and distribution of natural gas under high-pressure conditions were necessary. Under these conditions, it was found that the production and transmission pipelines were becoming blocked with what looked like to be ice. Hammer schmidt [1934] determined that hydrates were the cause of plugged natural gas pipeline [1, 2].

Prediction of gas hydrate formation rate (HFR) plays an important role in developing models that can describe and predict the hydrate formation processes and also in studying the mechanisms of nucleation and growth of hydrate plugs in pipelines, thus several researches have been performed on the measurement and modeling of hydrates formation rate based on the hydrate-former gases consumption values [3, 4, 5, 6].

Several processes were investigated in order to prevent and/or combat hydrate plugs and ensure regular flow: chemical, hydraulic, thermal and mechanical processes. The chemical method consists in injecting chemicals in the pipeline. These chemicals fall into three classes: Thermodynamic hydrate Inhibitors (THIs), Kinetic Hydrate inhibitors (KHIs) and anti agglomerants (AAs) [7,8]. Unlike the THIs, the KHIs (generally polymers) do not alter the thermodynamics of hydrate formation but instead, modifies the kinetics of hydrate formation by preventing nucleation or by

hindering or slowing down the crystal growth[Sloan,1997].Talaghat[2010] proposed a new Rate equation to predict gas consumption rate during hydrate formation in the Presence of kinetic Inhibitors(PVP and L-Tyrosine)[9].(the so called “Talaghat-model”).

However, these presented models are not accurate enough to predict HFR in pipelines and often consider only simple pure gases. Most of them require complex and time consuming computations and also a lot of input information to achieve the answer.

Based on the above discussion, it is obvious that there is a research requirement for developing new models. These models should not have the limitations and complexities of the available models. In other words the new models should be more accurate, robust and less sensitive to noisy input data, adaptive to a new input-output information and also should require the least amount of input information. Intelligent models offer all of the above desirable characteristics. One of the first studies in this regard was performed by Blusari[1995] that in this work proposed a new book as artificial neural networks for chemical engineers [10].In this work rate models of hydrate formation for a pure gas component (such as C1, C3, i-C4 and CO₂) with presence of kinetic hydrate inhibitors were developed. The kinetic inhibitors are PVP and l-tyrosine. Therefore, The main objective of this study was to present models of (Adaptive Network–Based Fuzzy Inference System) ANFIS and (Multi-layer Perceptron) MLP for predicting the HFR of common hydrate-former gases (C1, C3, i-C4 and CO₂), in the Presence of kinetic Inhibitors using experimental data obtained from flow mini-loop apparatus.

2. Artificial neural networks (multi-layer network)

The study of neural networks (NNs) was inspired by biological NNs, and founded on a semi-empirical base to model the behavior of the biological nerve cell structure. The processing elements or neurons in a NN

simulate the function of the nerve cells in human brain that contains billions of interconnected neurons. These neurons are the fundamental elements of the central nervous system and determine any action that is taken. Artificial neural networks (ANN) are computing systems made up of a number of simple, highly interconnected processing elements, which process information by their dynamic state response to external inputs. The fundamental concept of neural networks is the structure of the information processing system. Generally, an ANN is made of an input layer of neurons, sometimes referred to neurons or processing elements (PEs), one or several hidden layers (HLs) of neurons and output layer of neurons. The neighboring layers are fully interconnected by weight. The input layer neurons receive information from the outside environment and transmit them to the neurons of the hidden layer without performing any calculation. Layers between the input and output layers are called HLs and may contain a large number of hidden processing units. Finally, the neurons of output layer produce the network predictions to the outside world. Each neuron of a layer other than the input layer computes first a linear combination of the outputs of the neurons of the previous layer, plus a bias. The coefficients of the linear combinations plus the biases are called weights. Then, neurons in the HL apply a nonlinear function as activation function to their inputs [11,12].

3. Adaptive Neural-Fuzzy Inference System (ANFIS)

ANFIS is the famous hybrid neural-fuzzy network for modeling the complex systems. ANFIS incorporates the human-like reasoning style of fuzzy systems through the use of fuzzy sets and a linguistic model consisting of a set of IF–THEN fuzzy rules. The main strength of ANFIS models is that they are universal approximators with the ability to solicit interpretable IF– THEN rules [13].

Suppose that the rule base of ANFIS contains two fuzzy IF–THEN rules of Takagi and Sugeno’s type as follows:

Rule1: If x is A_i and y is B_i THEN $f_i=p_i x + q_i y + r_i$

ANFIS architecture is shown in Figure1. The functions of each layer are described as follows:

Layer 1 – Every node i in this layer is a square node with a node function:

$$O_i^1 = \mu_{A_i}(x) \tag{1}$$

Where x is the input to node i , and A_i is the linguistic label (fuzzy sets: small, large.) associated with this node function. Layer 2 – Every node in this layer is a circle node labeled Π which multiplies the incoming signals and sends the product out [16,17]. For instance,

$$O_i^2 = W_i = \mu_{A_i}(x) \times \mu_{B_i}(y) \quad , \quad i=1,2,\dots,n \tag{2}$$

Each node output represents the firing weight of a rule. Layer 3 – Every node in this layer is a circle node labeled N . The i th node calculates the ratio of the i th rule’s firing weight to the sum of all rule’s firing weights:

$$O_i^3 = \bar{w}_i = \frac{w_i}{\sum_{i=1}^n w_i} \quad , \quad i=1,2,\dots,n \tag{3}$$

Layer 4 – Every node in this layer is a square node with a node function:

$$O_i^4 = \bar{w}_i f_i = \bar{w}_i (p_i x + q_i y + r_i) \quad , \quad i=1,2,\dots,n \tag{4}$$

Where W_i is the output of layer 3, and $\{p_i, q_i, r_i\}$ is the parameter set.

Layer 5 – The signal node in this layer is a circle node labeled Σ that computes the overall output as the summation of all incoming signals, i.e.,

$$O_i^5 = \sum_{i=1}^n \bar{w}_i f_i \quad , \quad i=1,2,\dots,n \tag{5}$$

4. Development of ANFIS and MLP models

To develop models of ANFIS and MLP , 479 data (Table1) was used and with a random selection, 359 of data was used as train set data and the 120 remaining data was used as test set data. Choosing this configuration was done based on trial and error procedure to achieve best results.

To develop an Intelligent System, the most important physical skill required is to make a decision what the principal inputs and output(s) of the system are. In this study, the inputs to the present Models were temperature, pressure, molecular weight of hydrate-former, time and concentrations of the KHIs. The desirable output of the models was the hydrate formation rate (gas consumption amount). To achieve this goal, two models of ANFIS and MLP were designed.

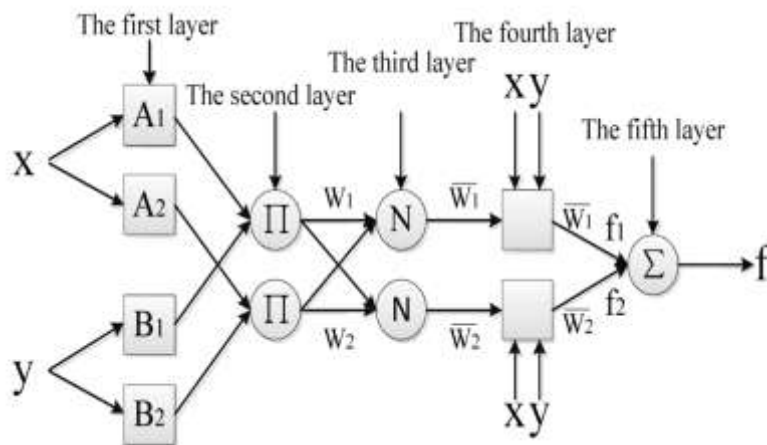
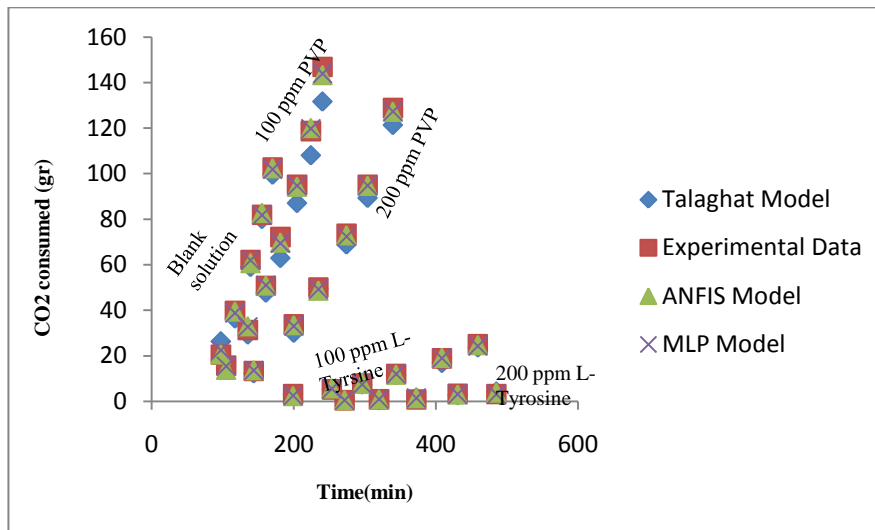
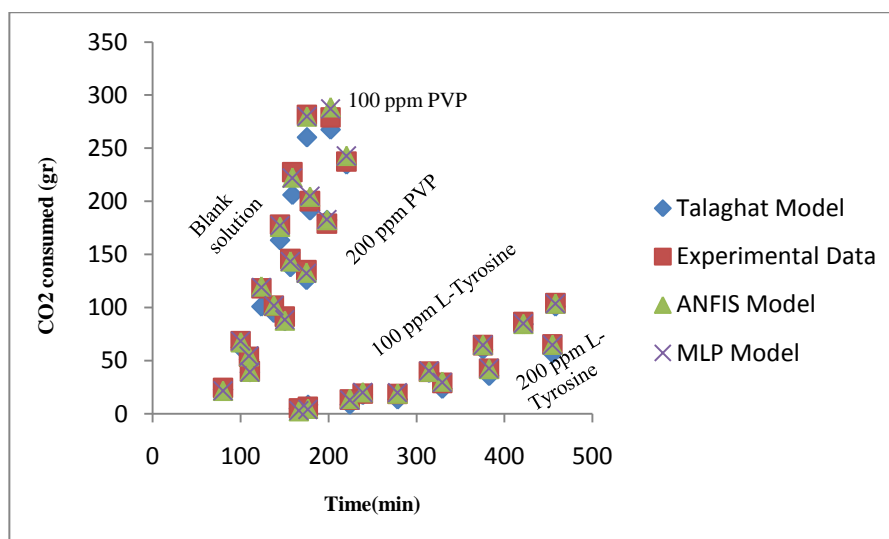

Figure 1: Schematic of ANFIS architecture

Table1: Ranges of the input variables used in developing the ANFIS and MLP models

Parameter	Hydrate-Former	Minimum	Maximum
Temperature (K)	C1, C3	277.15	277.15
	i-C4	275.15	275.15
	CO2	280.15	280.15
Pressure (Mpa)	C1	5	8
	C3	1	2
	i-C4	1	2
	CO2	4	7
Molecular Weight (gr/mol)	C1,C3, i-C4, CO2	16.043 (C1)	58.123 (i-C4)
Time (min)	C1,C3, i-C4, CO2	0	485
PVP concentration(ppm)	C1,C3, i-C4, CO2	0	200
L-Tyrosine concentration(ppm)	C1,C3, i-C4, CO2	0	200

**Figure 2: results of testing ANFIS and MLP models for the rate of CO₂ hydrate formation as a function of time at a 280.15K and 4 Mpa****Figure3: Results of testing ANFIS and MLP models for the rate of CO₂ hydrate formation as a function of time at 280.15 K and 7 Mpa**

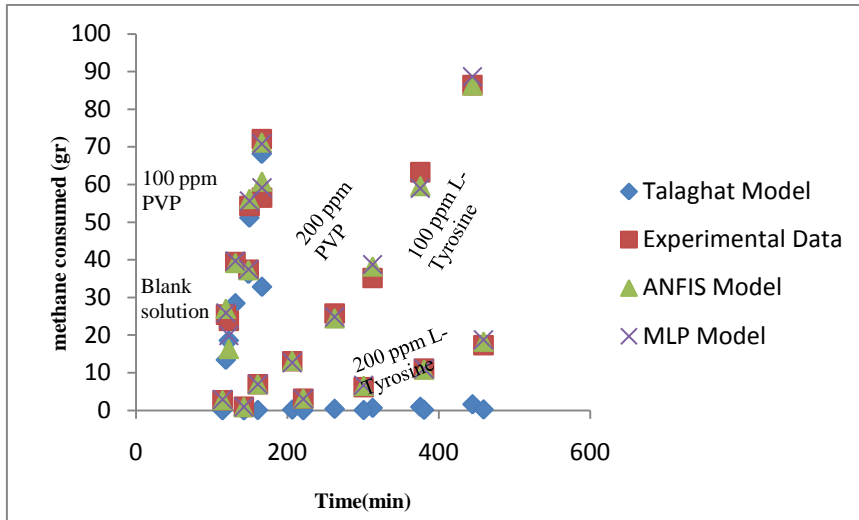

Figure4: Results of testing ANFIS and MLP models for the rate of methane hydrate formation as a function of time at 277.15 K and 8Mpa

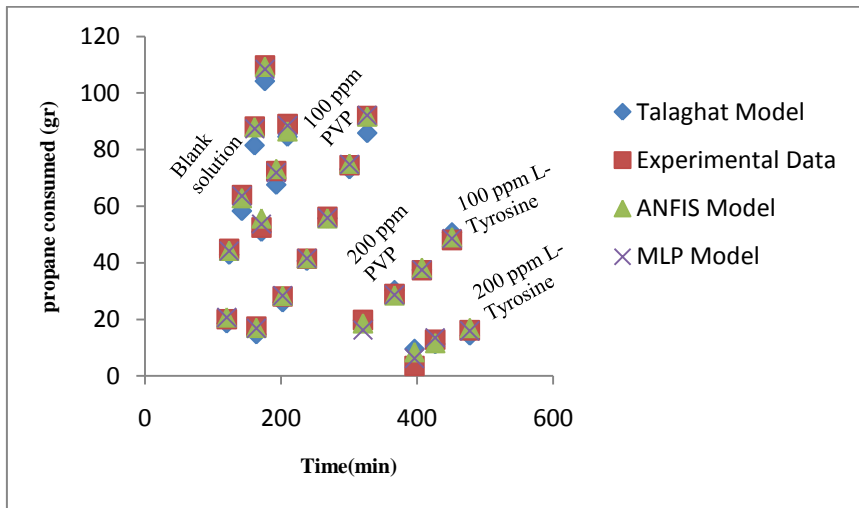

Figure5: Results of testing ANFIS and MLP models for the rate of propane hydrate formation as a function of time at 277.15 K and 1.5Mpa

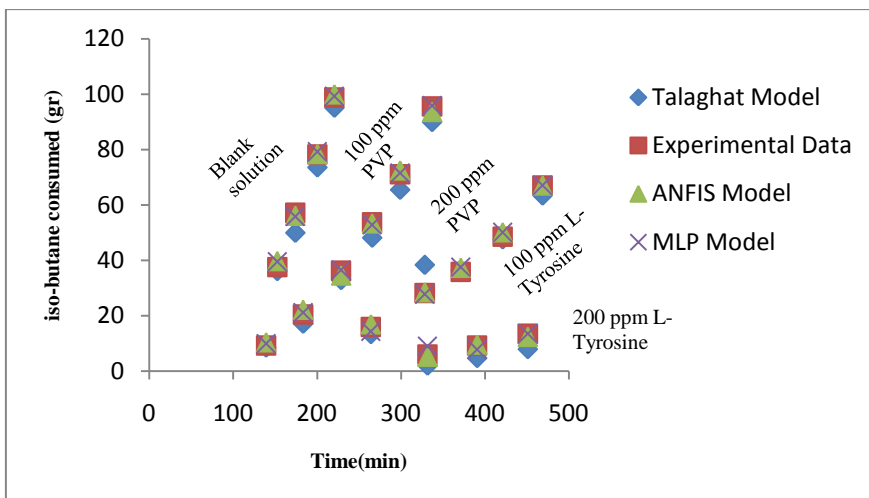

Figure6: Results of testing ANFIS and MLP models for the rate of iso-butane hydrate formation as a function of time at 275.15 K and 2Mpa

In MLP model, HFR was a function of temperature (T), pressure (P), molecular weight of hydrate-former (MW_{hf}), time (t), PVP_{CONC} and $L - Tyrosine_{CONC}$ therefore, the model has 6 and 1 neurons in its input and output layers, respectively:

$$HFR = f_{MLP \text{ and } ANFIS}(T, P, MW_{hf}, t, PVP_{CONC}, L - Tyrosine_{CONC}) \quad (5)$$

Based on the importance of optimum architecture determination in developing multi-layer neural networks (Engelbrecht, 2007), four elements that contain these architectures have been investigated to developed the desirable models: 1) number of hidden layers, 2) number of neurons in each hidden layer, 3) activation function of each layer and 4) training algorithm, which determines the final value of the weights and biases.

Several neural network architectures were tested to find out the best accuracy. Finally, a multi-layer network with two hidden layers was found to be suitable to consider the relationship indicated in equation (5). The optimum numbers of the neurons in the first and second hidden layers were determined 18 and 5 and tangent-sigmoid and linear transfer functions were used as activation (transfer) functions of the hidden layers and output layer, respectively. In the network were developed in this study, the Bayesian regularization (automated determination of optimal regularization parameters) in combination with Levenberg-Marquardt training algorithm, was used to improve the generalization power of ANN. This kind of regularization has been implemented in the function "trainbr".

ANFIS model on the basis of the subtractive clustering algorithm with inputs and output similar to MLP model was developed. The fuzzy HFR modeling system used in this study is a multi-input single output (MISO) Takagi-Sugeno system. Because of large number of input variables, scatter partitioning was used to

avoid "curse of dimensionality" problem instead of grid partitioning.

Table 2 shows the details of optimal fuzzy model designed for ANFIS model. This arrangement resulted by trial and error procedure. Hybrid optimization method was used to optimize generated fuzzy inference systems (FIS) and the best models of ANFIS and MLP were selected according to minimum total average absolute deviation percent (TAAD%):

$$TAAD\% = \frac{100}{N} \times \left| \frac{\sum_{i=1}^N (y_i^{exp} - y_i^{cal})}{y_i^{exp}} \right| \quad (6)$$

Where y_i^{exp} and y_i^{cal} are target and model output for the i th output, and N is the total number of events considered.

Table2: Characteristics of fuzzy model for ANFIS model.

Parameter	Operator
AND	prod
OR	probor
Implication	prod
Aggregation	max
Difuzzification	wtaver

5. Result and discussion

In this work, ANFIS and MLP models were used to predict gas hydrate formation rate. Data needed to design and train the presented model were extracted and collected from articles which investigate the phenomenon of hydrate formation in laboratory-scale [9].

Table 3 shows the features and functions of designed models compared with the actual results and the latest presented model (talaghat model). TAAD% is the overall average of absolute deviation for normalized data and R is the correlation coefficient for normalized data.

Based on obtained results, designed ANFIS and MLP models are more accurately able to predict gas hydrate formation rate than Talaghat model. The related TAAD% for ANFIS and MLP models were 5.3964 and 5.8196 %, respectively.

respectively. On the other hand, ANFIS model is more accurate than MLP model because of the integration of fuzzy logic systems with the capability of learning in artificial neural networks which leads to the adaptability of the model with this issue.

Table3: Error analysis of different models

	TAAD%	R
ANFIS	5.3964	0.9995
MLP	5.8196	0.9994
Talaghat-Model	15.8	0.9815

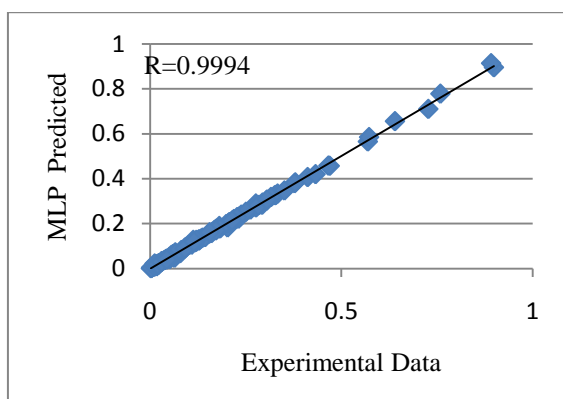

Figure 8: Experimental data versus MLP model outputs

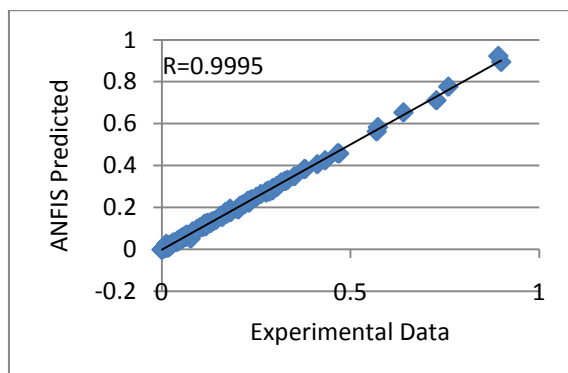

Figure 9: Experimental data versus ANFIS model outputs

Figures 2 to 6 show the results of testing for ANFIS and MLP models, along with Talaghat experimental model compared

References:

1. Sloan, E. D., (1997). "Clathrate hydrates of natural gases. New York: Marcel Dekker."
2. Talaghat, M. R. (1988). "Experimental Investigation of Natural Gas Components During Gas Hydrate Formation in Presence or Absence of the L-Tyrosine as a Kinetic Inhibitor in a Flow Mini-loop Apparatus." *J Chem Petroleum Eng, University of Tehran*, Vol. 45, No.2, December 2011, PP. 153-166.

with experimental results in this study, moreover, four different types of fuzzi component gas hydrates, including CO₂, C₁, C₃, and i-C₄ at different pressures are illustrated.

In Figures 7 and 8, actual results against outputs for MLP and ANFIS models are respectively show, moreover, they are efficient and consistent.

6. Conclusions

Gas hydrate formation in production and transmission pipelines and consequent plugging of these lines have been a major flow-assurance concern of the oil and gas industry for the last 75 years. Gas hydrate formation rate is one of the most important topics related to the kinetics of the process of gas hydrate crystallization. In this work, utilization of the adaptive neural fuzzy inference system and Artificial Neural Network (Multi-layer Perceptron) techniques for predicting the hydrate formation rate has been investigated.

Based on these results the following conclusions can be noted:

1. Our comparison among experimental results, mlp, neural-fuzzy and Talaghat models shows that prediction of designed models is well matched with experimental data so that they are over 2 to 3 times more accurate than Talaghat model.
2. Comparing obtained results determines that ANFIS model is more accurate than other models (MLP and Talaghat models) to predict gas hydrate formation.

The ANFIS and MLP models can be used to predict the hydrate formation rate of the hydrate-formers C₁, C₃, i-C₄ and CO₂ when the operational conditions conform to the ranges of the input data was used to develop these models.

3. Vysniauskas, J. W., and Bishnoi, P. R. (1983). "A kinetic study of methane hydrate formation." *Chem Eng Sci*, No. 38, PP. 1061–1072.
4. Kamari, E., Mohammadi, S., Ghozatloo, A., and Shariaty-Niassar, Mo. "Development of Hydrate Formation Phase Envelope: An Experimental Approach in One of the Iranian Gas Reservoirs". *J Chem Petroleum Eng, University of Tehran*, Vol. 47, No. 2, PP. 115-127.
5. Skovborg, P., and Rasmussen, P. (1994). "A mass transport limited model for the growth of methane and ethane gas hydrates" *Chem Eng Sci*, No. 49, PP. 1131–1143.
6. Kashchiev, D., and Firoozabadi, A. (2003). "Induction time in crystallization of gas hydrate" *J Crystal Growth*, No. 250, PP. 499–515.
7. Mokhatab, S., Wilkens, R. J., and Leontaritis, K. J. (2007). "A review of strategies for solving gas-hydrate problems in subsea pipelines, recovery utilization and environmental effects". *Energy Sources part A*. No. 29, PP. 39-45.
8. Zhang, C. S., Fan, S. S., Liang, D. Q., and Guo, K. H. (2004). "Effect of additives on formation of natural gas hydrate". *Fuel*, No. 83, PP. 2115-2121.
9. Talaghat, M. R., Esmailzadeh, F., and Fathikalajahi, J. (2010). "Experimental and theoretical investigation of simple gas hydrate formation in presence of kinetic inhibitors in a flow mini-loop apparatus". *Fluid Phase Equilibria*, No. 279, PP. 28–40.
10. Blusari, A. B. (1995). "Neural networks for chemical engineers". *Amsterdam: Elsevier Science Press*.
11. Graupe, D. (2007). "Principles of artificial neural networks." *Singapore: World Scientific Publishing Co*.
12. Shadravanan, R., Schaffie, M., and Ranjbar, M. (2010). "Prediction of Hydrate Formation Rate in the Presence of inhibitors". *J Energy Sources, Part A*.
13. Jang, J. S. R. (1993). "ANFIS: Adaptive-network-based fuzzy inference system". *IEEE Trans. Syst. Man Cyber*. No. 23, PP. 665–685.